

# CUTSFORTH

THE POWER OF INNOVATION™

## Shaft Grounding System

EGSA-001

THE INFORMATION CONTAINED HEREIN IS  
CONFIDENTIAL AND PROPRIETARY TO  
CUTSFORTH INC. AND SHALL NOT BE  
REPRODUCED OR DISCLOSED IN WHOLE OR  
PART FOR ANY DESIGN OR MANUFACTURE  
WITHOUT THE WRITTEN AUTHORIZATION OF  
CUTSFORTH INC.

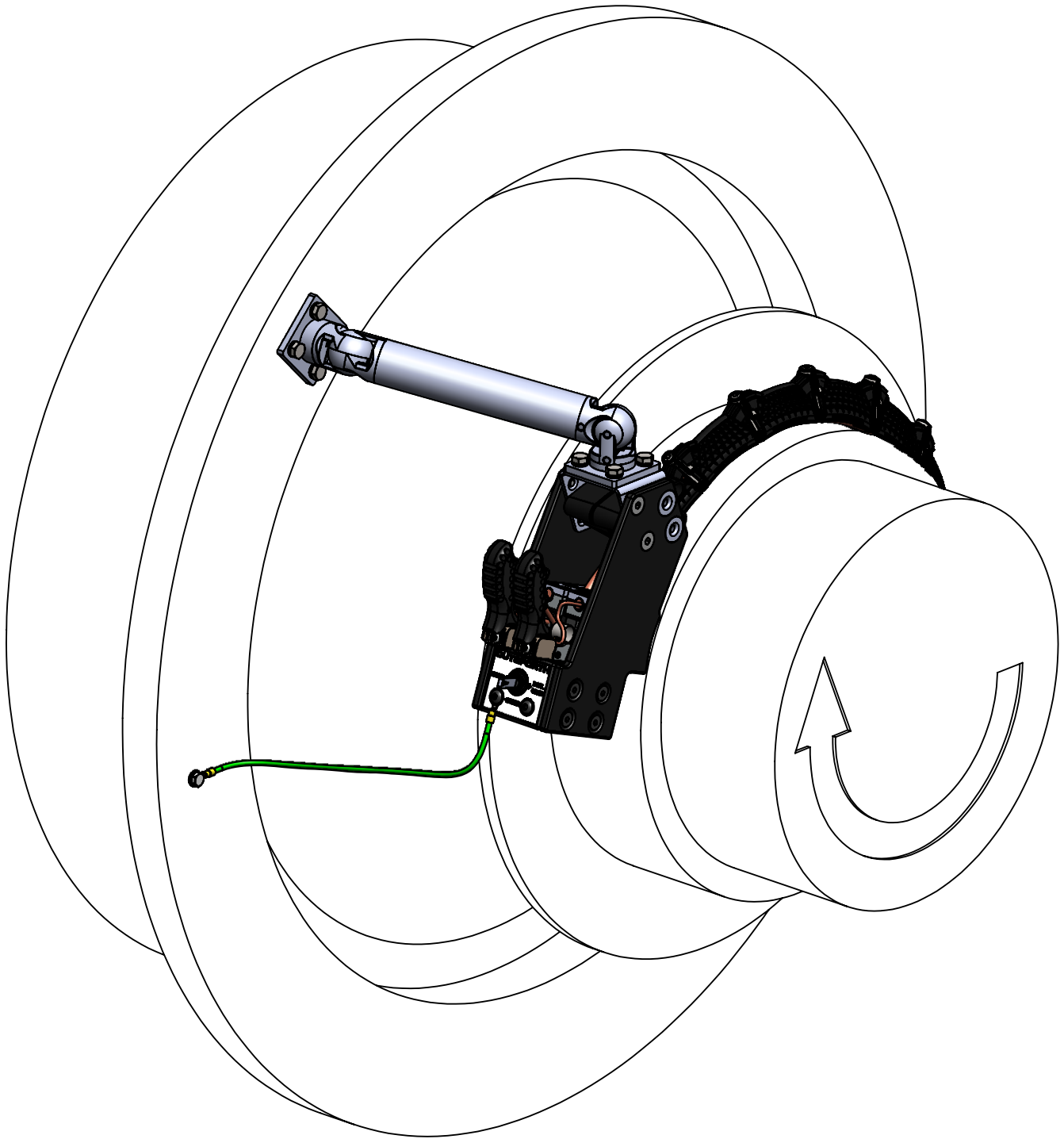

## Components of the Shaft Grounding System

No.	Description
1	Metering Switch
2	Brush Spring*
3	Wear Indicator*
4	Removable Brush Holder
5	Attachment Arm
6	Guide Assembly
7	Copper Rope*
8	Shaft (existing equipment)
9	Graphite Lube Brush*
10	Grounding Wire (attachment location may vary)
11	Voltage Metering Test Points
*	EGHK-003 Maintenance Replacement Kit

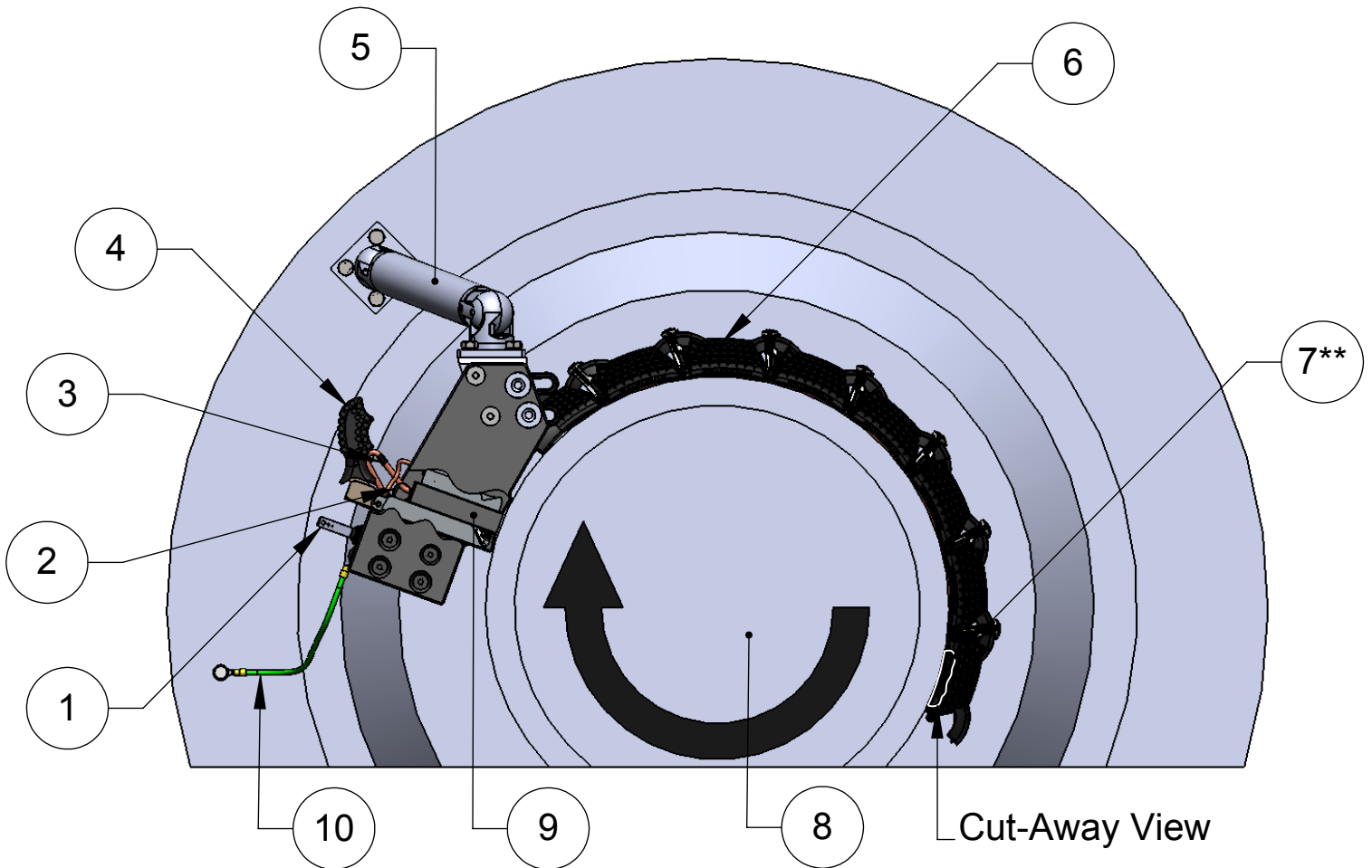
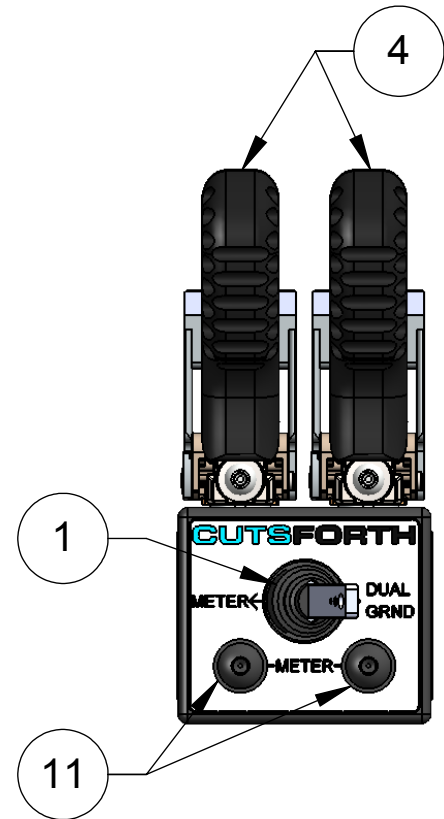

\*\*Copper Rope terminates approximately halfway inside the last section of the Guide Assembly.

## Operational Characteristics:

Normal operating shaft voltage is less than 10 volts DC peak-to-peak.

Voltages increasing beyond the normal operating voltage, but less than 10 VDC peak-to-peak, will generally not cause bearing damage. However, the increase in voltage does begin to indicate problems. For example: poor shaft grounding from dirty shaft contact surface, generator magnetic dissymmetry, generator excitation rectifier failure, turbine blade wear, failed bearing insulation, etc.

Normal operating shaft current is less than 4 amps DC.

Current increasing beyond the normal operating current, but less than 4 ADC, will generally not cause bearing damage. However, the increase in current does begin to indicate the problems described above.

Continuous operation above 10 VDC peak-to-peak or 4 ADC can result in significant shaft bearing damage.

## Monitoring Recommendations:

Voltage and current measurements should be performed at intervals required by the turbine/generator OEM. These results will give indications of trouble and needed maintenance. Meter devices such as an ungrounded oscilloscope, high-speed strip chart style recorder, or analog DC voltmeter (mV-600 VDC) can be used to measure shaft voltage. The shaft voltage is measured by setting the switch to the left ("METER") and placing the leads from the meter device on the two test points. A typical digital multimeter is not recommended for measuring voltage as the results can be unreliable and quick-acting noisy voltage spikes can be missed altogether.

To measure current, additional modifications to the shaft grounding system are needed.

## Maintenance Recommendations:

The brushes and copper ropes need to be monitored for wear and replaced when the brush is worn past the wear indicator on the copper lead, or the copper rope is worn through more than a third of the diameter. The replacement kit part number is EGHK-003 and is available from Cutsforth at (800) 290-6458 or [sales@cutsforth.com](mailto:sales@cutsforth.com)

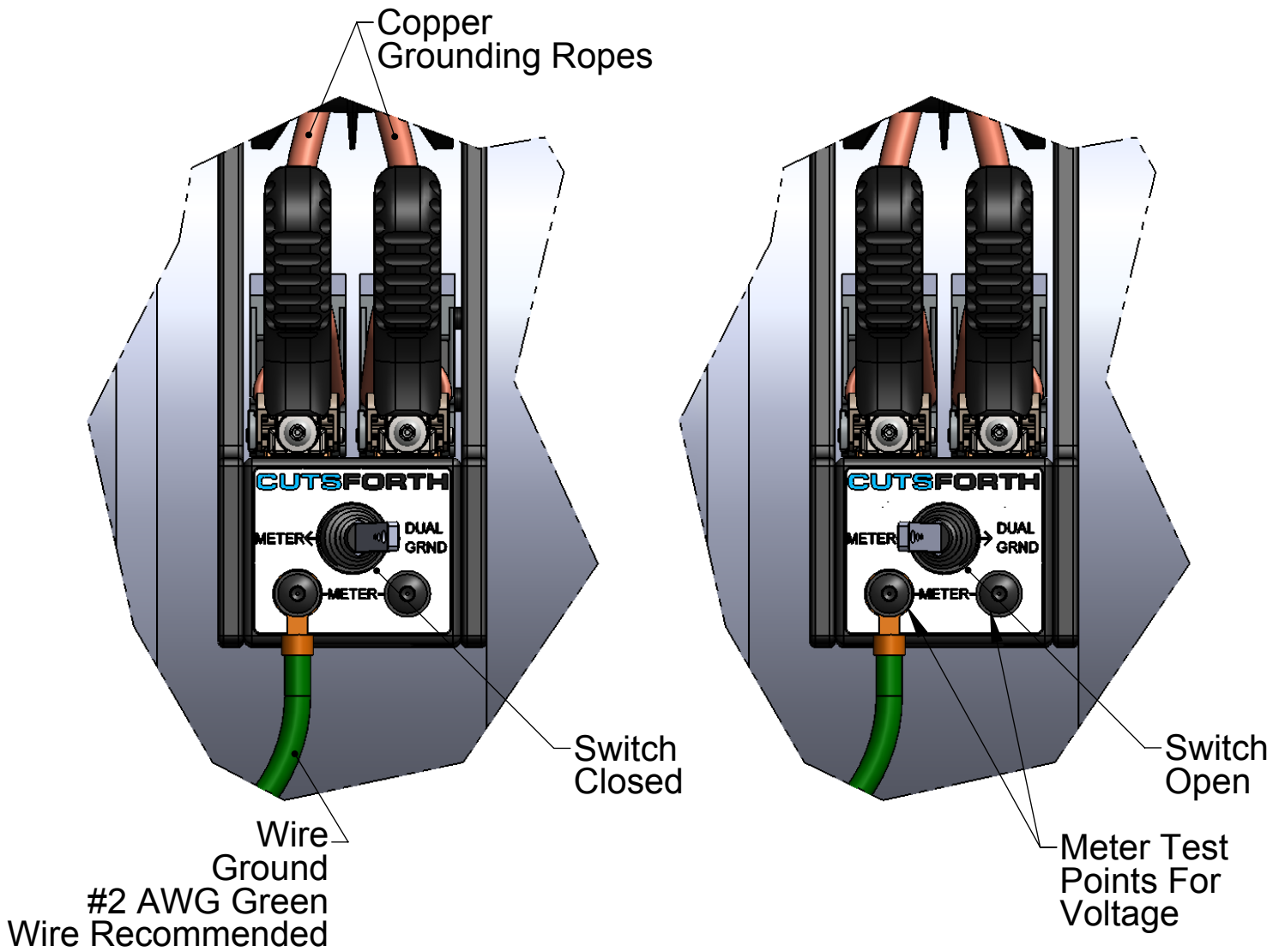

## Dual Ground Setting

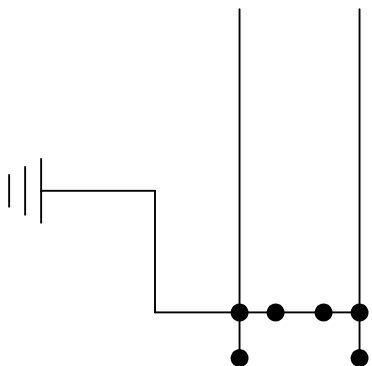

## Meter Setting

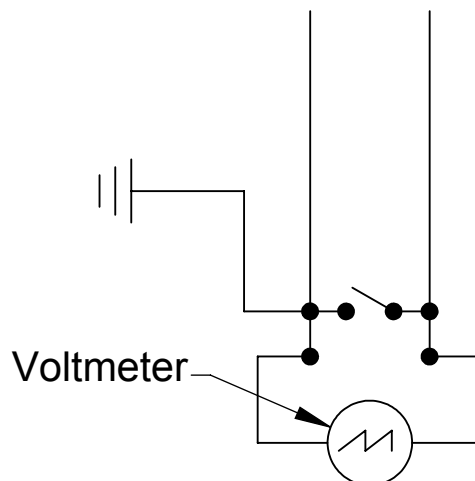

## Shaft Grounding Location Diagram

